

# Released Assessment Questions, 2018

# ANSWERS

Grade 9 Assessment of Mathematics • Academic

## DIRECTIONS

### Answering Multiple-Choice Questions

Answer all multiple-choice questions. If you fill in more than one answer to a question, or leave a question blank, the question will be scored zero. Incorrect answers will also be scored zero.

### Answering Open-Response Questions

Do all of your work for each question in the space provided for the question **only**.

Write your solutions, including all calculations, clearly and completely.

### ATTENTION:

There are more open-response questions in this booklet than a regular booklet.

**Record ALL  
your answers to  
multiple-choice and  
open-response questions  
in this booklet.**

Education Quality and  
Accountability Office



**You are now ready to start.**



Please read the questions in the *Question Booklet*; then fill in your answers below.

To indicate your answer, use a pencil to fill in the appropriate circle below completely.

Like this: ●

Not like this: ⊗ ✓ ◐ ○

Cleanly erase your answer if you wish to change it and fill in the circle for your new answer.

Fill in only **one** circle for each question.

**1** (a) (b) (c) (d)

**2** (a) (b) (c) (d)

**3** (a) (b) (c) (d)

**4** (a) (b) (c) (d)

**5** (a) (b) (c) (d)

**6** (a) (b) (c) (d)

**7** (a) (b) (c) (d)

**8 Square Removed**

This rectangle has a square removed. There are algebraic expressions for the sides, in centimetres.

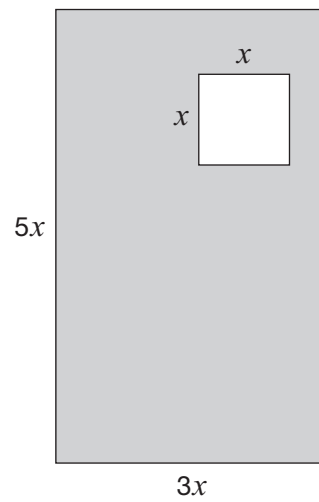

The area of the rectangle without the square is  $126 \text{ cm}^2$ .

Determine the side length of the square,  $x$ , in centimetres.

Show your work.

The side length of the square,  $x$ , is \_\_\_\_\_ cm.

**9 How Fast Can You Ski?**

This scatter plot shows the relationship between the distance a downhill skier is from the bottom of a ski hill and the amount of time the skier has been on the hill.

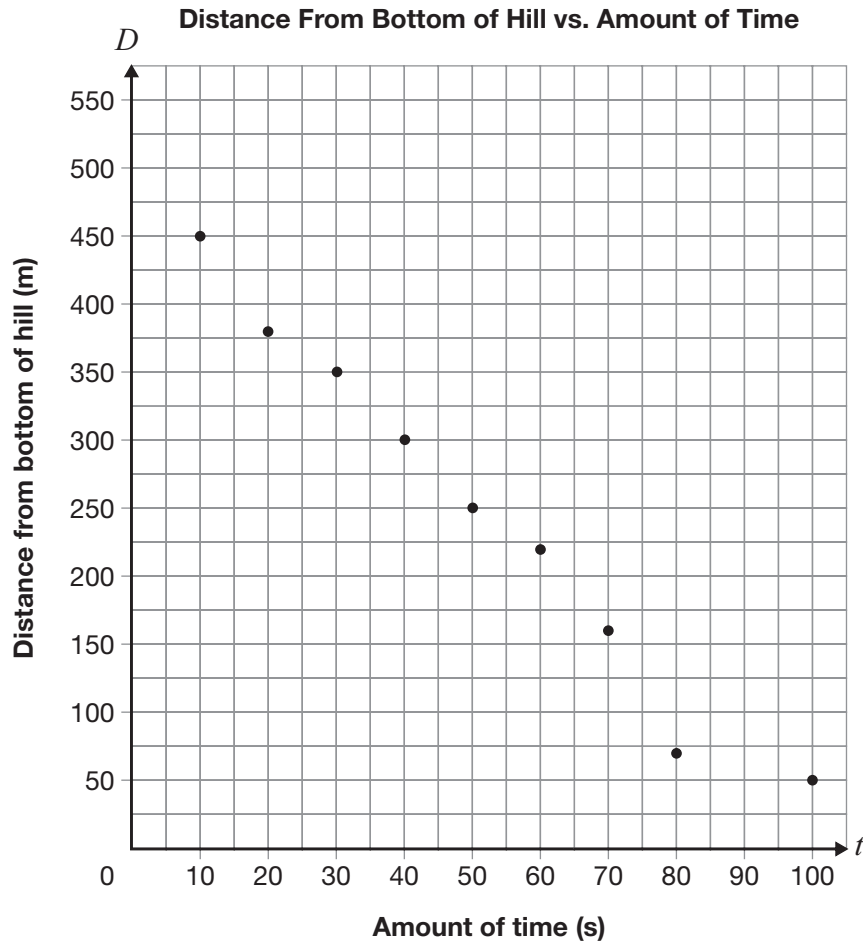

Draw an appropriate line of best fit for the data.

Determine an equation for your line of best fit.

Show your work. If using technology, provide support to show why your answer is correct.

$D =$  \_\_\_\_\_

**10 Tree Planting**

A high school’s environmental club is selling trees to raise money. The club starts with a donation from the principal and then collects money for each tree it sells.

Information about the linear relationship between the total amount raised and the number of trees sold is given.

Graph all the data from the table on the grid. Include an appropriate scale on the vertical axis.

Number of trees sold, $n$	Total amount raised, $A$ (\$)
3	240
9	420
11	480

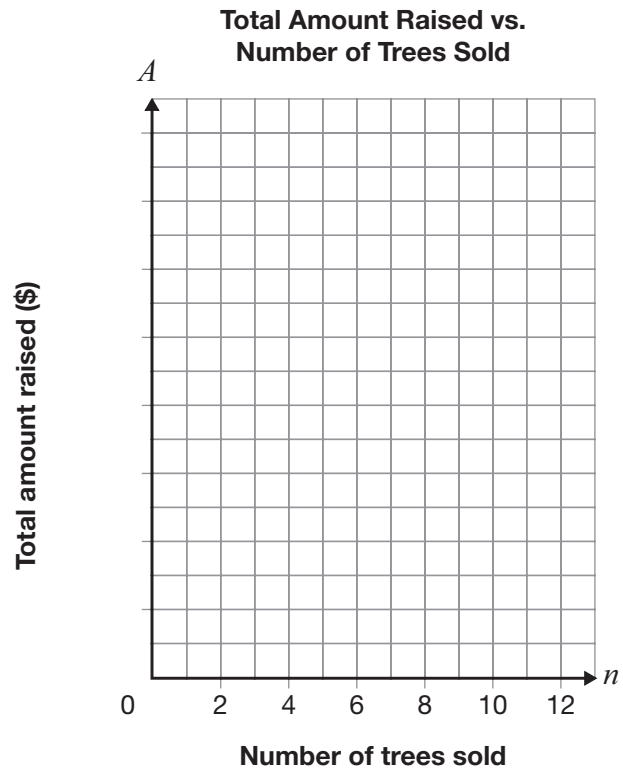

Determine an equation to represent the relationship between the total amount raised,  $A$ , and the number of trees sold,  $n$ .

Show your work.

$A =$  \_\_\_\_\_

**11 Comparisons**

Line segment AB has a slope of  $\frac{5}{8}$ .

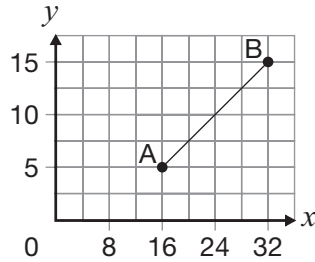

Slope of  $\overline{AB} = \frac{5}{8}$

Determine the slope of line segments EF, GH and JK below.

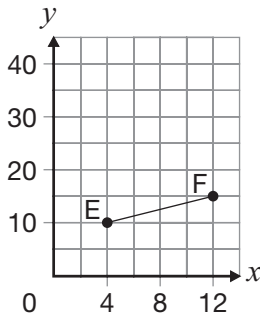

Slope of  $\overline{EF} =$  \_\_\_\_\_

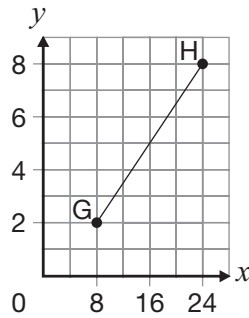

Slope of  $\overline{GH} =$  \_\_\_\_\_

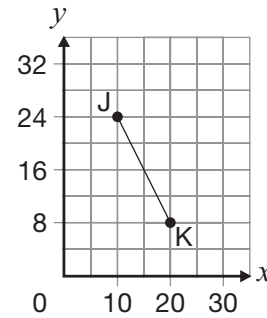

Slope of  $\overline{JK} =$  \_\_\_\_\_

Complete the chart by comparing the slope of each of line segments EF, GH and JK to the slope of line segment AB if all the line segments were graphed on the same grid.

	Line segment EF	Line segment GH	Line segment JK
<b>Comparison to line segment AB</b>	Circle one: parallel perpendicular neither	Circle one: less steep more steep same steepness	Circle one: parallel perpendicular neither

**12 The Better Choice**

Shane has a choice between two jobs helping people around his neighbourhood.

- **Job A:** Shane's total pay is shown on the grid below.
- **Job B:** Shane will receive base pay of \$30, plus \$12.50 per hour.

Determine the conditions under which Shane should select Job A and the conditions under which he should select Job B.

Justify your answer.

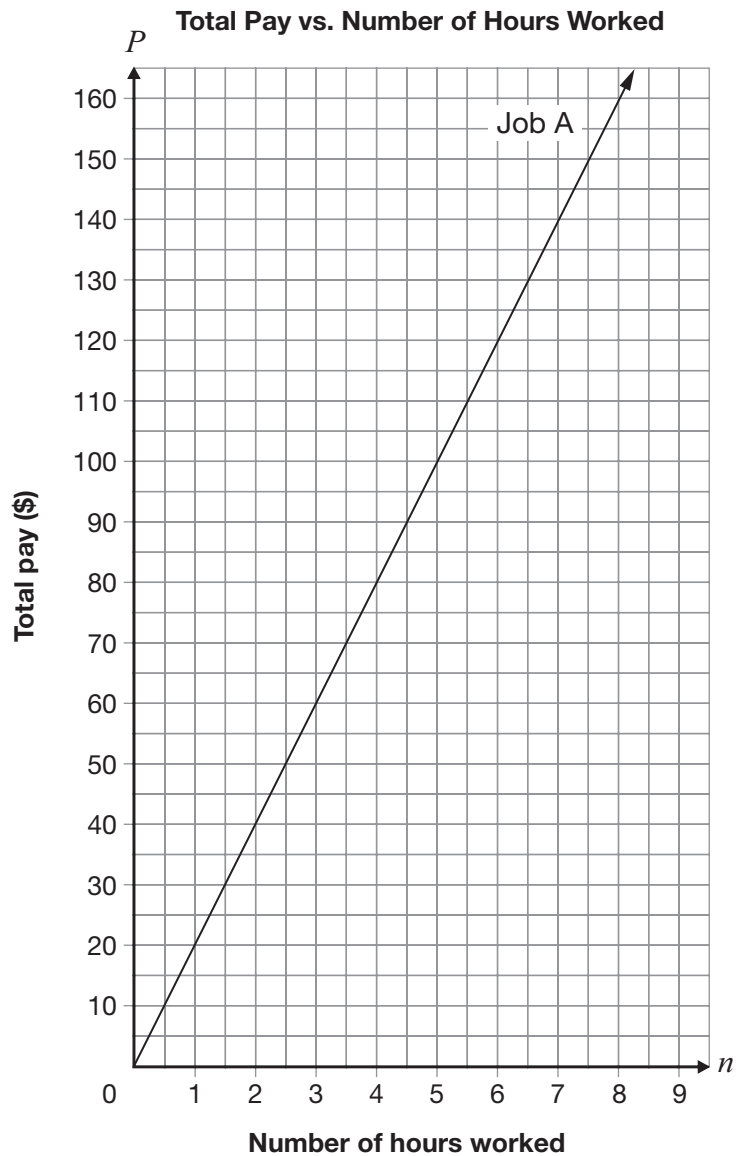

**13 What Height?**

Two containers are pictured below. One container is a cone, and the other is a rectangular-based prism.

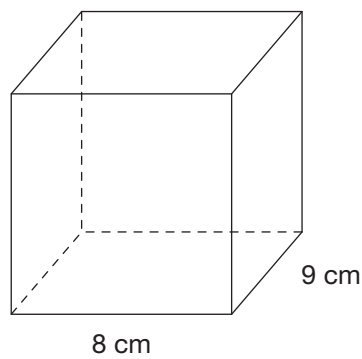
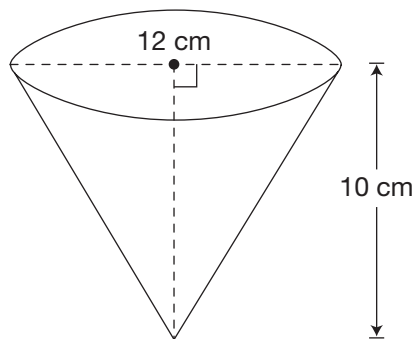

The cone is completely filled with water, and then the water is poured into the empty prism, without spilling.

Determine the height of the water in the prism.

Show your work.





Please read the questions in the *Question Booklet*; then fill in your answers below.

To indicate your answer, use a pencil to fill in the appropriate circle below completely.

Like this: ●

Not like this: ⊗ ✓ ◐ ○

Cleanly erase your answer if you wish to change it and fill in the circle for your new answer.

Fill in only **one** circle for each question.

14 (a) (b) (c) (d)

15 (a) (b) (c) (d)

16 (a) (b) (c) (d)

17 (a) (b) (c) (d)

18 (a) (b) (c) (d)

19 (a) (b) (c) (d)

20 (a) (b) (c) (d)

21 (a) (b) (c) (d)

22 (a) (b) (c) (d)